

## Fastener type HGW 30/ 60 g

### Advantages:

- quick mounting
- high distance balance
- installable in all positions
- anti-noise system
- fire-resistant

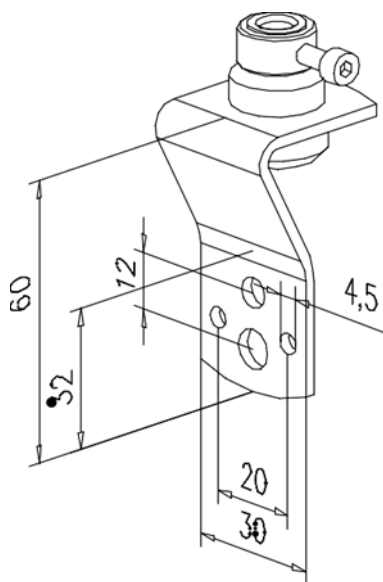

### Technical Data

- Fastener for rectangle tube, with rubber.
- For 6mm welding studs..
- Maximum recommended workload = 150 N / fastener

#### Dimensions:

L = 60mm  
other dimensions on request

#### Material:

- Galvanized steel (standard)

#### Rubber:

- 50 shore  $\pm$  5 standard

